



City of Milton-Freewater
Request for Proposals
Yantis Park ADA Improvements
Contract 306

DUE DATE/TIME: February 16, 2023 / 2:00 p.m. local time

SUBMITTAL LOCATION: City of Milton-Freewater, Public Works Department, Attn: Brian Steadman, brian.steadman@milton-freewater-or.gov, 501 Lamb Street, PO Box 6, Milton-Freewater, OR 97862. Proposals must be received at this location on or before said due date. Proposers are solely responsible for meeting this deadline. Email submittals are preferred.

PROJECT DESCRIPTION: The City of Milton-Freewater is seeking interested contractors to submit a bid proposal to complete ADA curb ramp and sidewalk improvements around Yantis Park. The project involves 9 locations around the park.

City Staff will demo the existing sidewalk/curb ramps, however the City will not remove curbing as some locations the curb can be cut instead of replaced. The selected contractor will be required to cut or replace curbs to meet ADA requirements, prepare gravel sub-grade at all locations, install curb ramps to ODOT standard drawings and specifications and install approximately 50 feet of 5-foot-wide sidewalk. See attachment A for project details.

This project, as part of a larger park improvement project, is an Oregon Bureau of Labor and Industries prevailing wage rate contract funded by City funds and a State of Oregon grant.

January 1 Wage Rates Apply: <https://www.oregon.gov/boli/employers/Pages/prevailing-wage-rates.aspx>

BIDDERS INFORMATION: Proposers responding to this request for qualifications do so solely at their expense and the Contracting Agency (City) is not responsible for any Proposer expenses associated with the Request for Proposals.

The Proposer declares and agrees that they will comply with all provisions of the Federal and State statutes and regulations pertaining to Workers Compensation, Industrial Accident Insurance, Income Tax Withholding, Social Security and payment of bills for labor and materials. Workers shall be paid not less than the specified minimum hourly rate of wage if the project is subject to the Prevailing Wage Rate Law.

To the extent applicable to Contractor or its subcontractors, workers shall be paid not less than the specified minimum hourly rate of wage if the project is subject to the Prevailing Wage Rate Law. ORS 279C.830 (1)(c); OAR 839-025-0020(2). Daily, weekly, holiday and weekend overtime will be paid ORS 279C.520; OAR 839-025-0020(1)(b).

If the Contractor fails to pay for labor or services the City shall pay and withhold these amounts from payments due to Contractor ORS 279C.515; OAR 839-025-0020(1)(a). The employer must give written notice to the workers of the number of hours per day and days per week they

RFP – 2023 Yantis Park ADA Improvements

Contract 306

Page | 1

may be required to work OAR 839-025-0020(1)(c). Contractor must make prompt payment for all medical services for which the contractor has agreed to pay and for all amounts for which the contractor collects or deducts from the workers wages. ORS 279C.530; OAR 839-025-0020(1)(d).

The Bidder declares and agrees that they will comply with all provisions of the Oregon Public Works Law as required by ORS 279.348 to 279.365 and all Federal and State statutes and regulations pertaining to Workers Compensation, Industrial Accident Insurance, Income Tax Withholding, Social Security and payment of bills for labor and materials. Workers shall be paid not less than the specified minimum hourly rate of wage if the project is subject to the Prevailing Wage Rate Law.

The City reserves the right to reject any or all qualifications, to postpone making the award for a reasonable length of time, or waive informalities, and to accept the qualifications deemed in the best interest of the City considering the experience and equipment of the bidders and the time required for completion.

ATTACHMENT A

Site 1:



Use ODOT Standard Drawing RD910 (reverse of photo below)

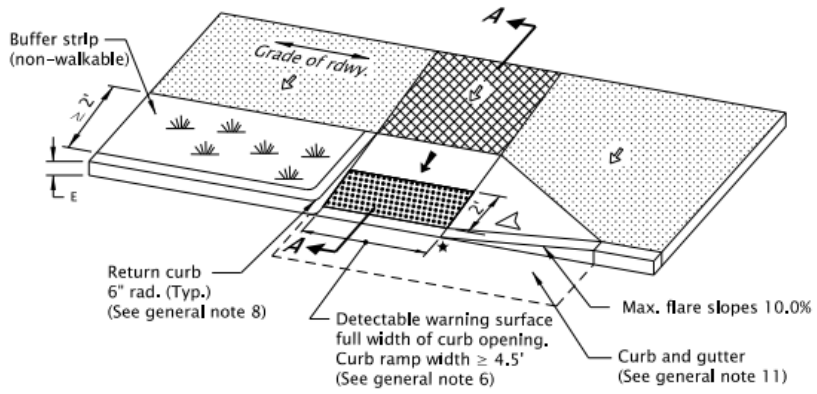

WITH SINGLE FLARE

Site 2:



Use ODOT Standard Drawing R920

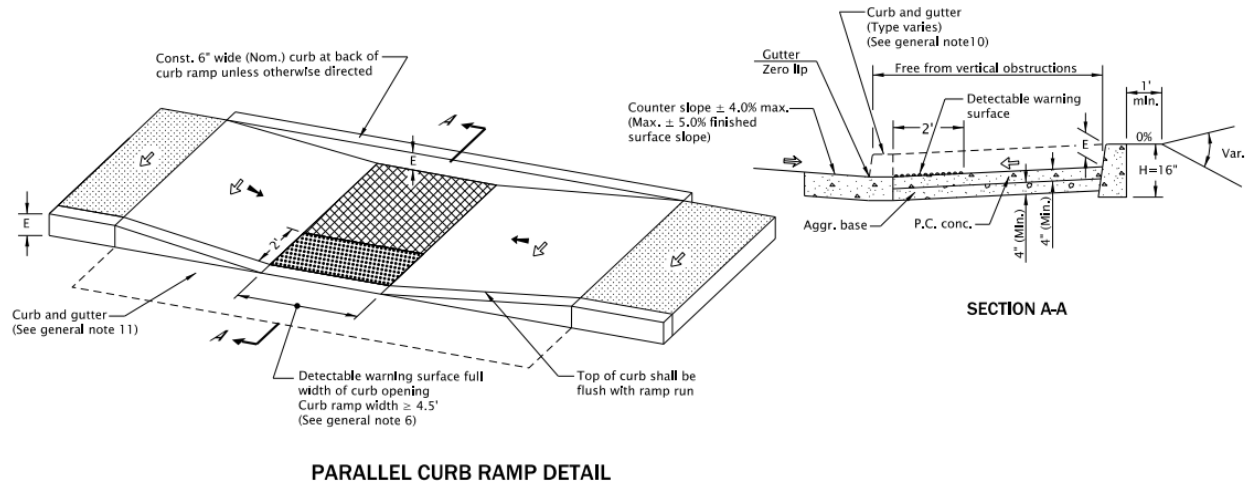

Site 3:



Use ODOT Standard Drawing RD735 Option G

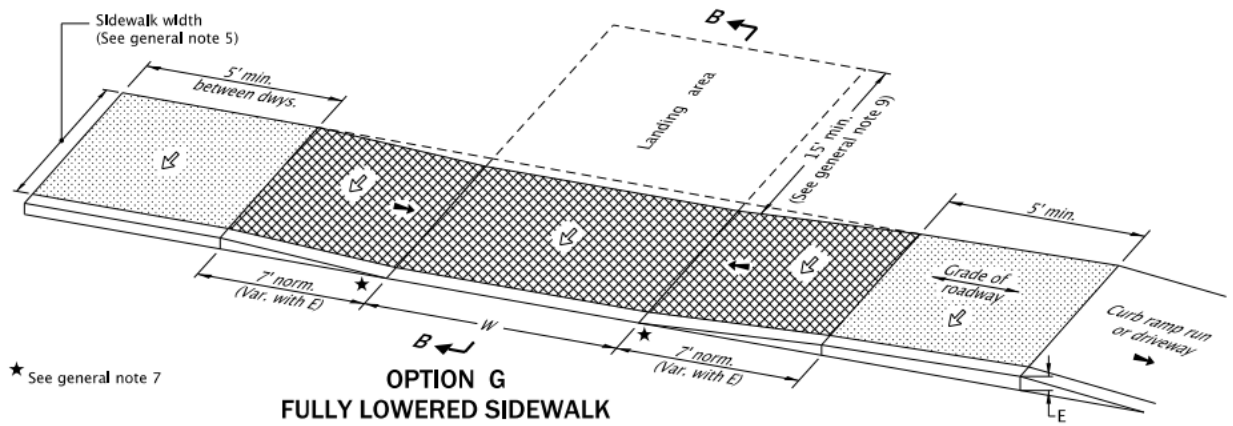

Site 4:



Use ODOT Standard Drawing RD735 Option G

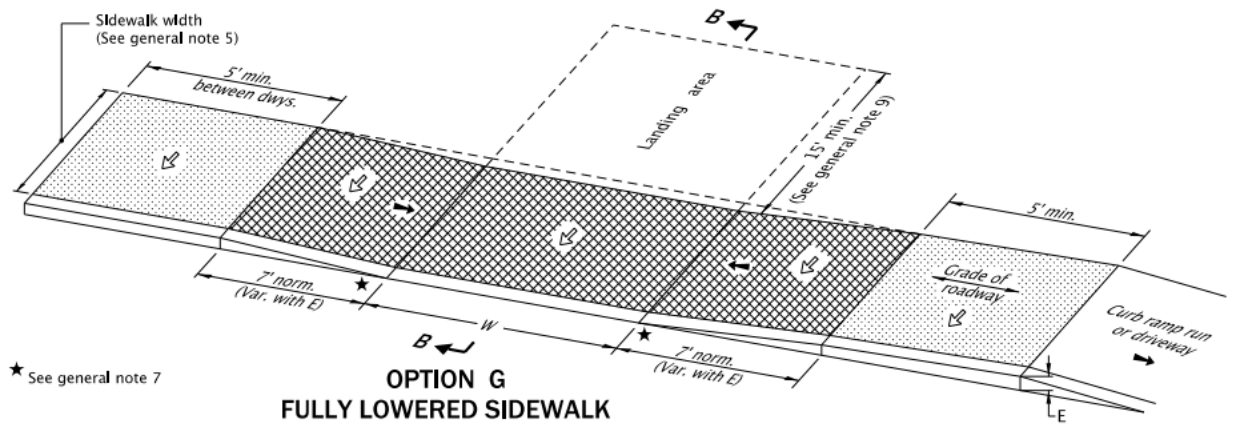

Site 5:



Install New (2) curb ramps at parking lot and playground curb and install connecting 5-foot-wide sidewalk.

Use ODOT Standard Drawing RD910

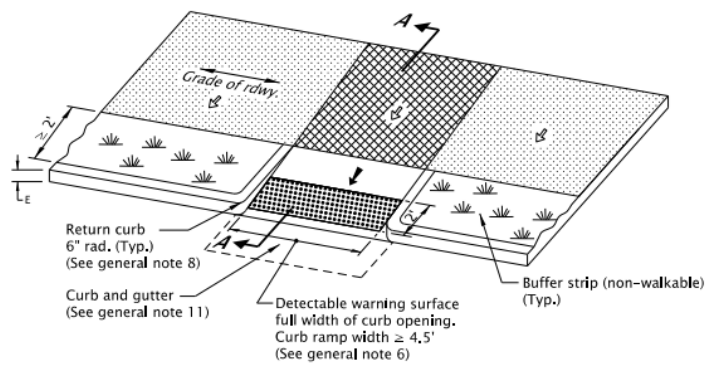

THROUGH BUFFER STRIP

Site 6:



Use ODOT Standard Drawing RD910 (Perpendicular curb ramp with 5 foot landing pad). This curb ramp is proposed to be wider, ~8', than standard to accommodate mower/park maintenance vehicles.

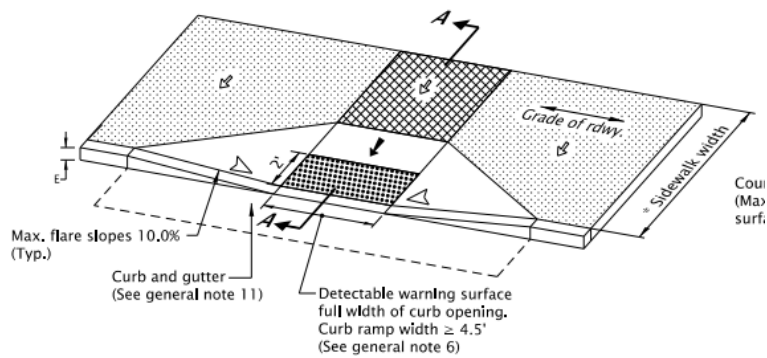

PERPENDICULAR CURB RAMP DETAIL

(Use "Parallel Curb Ramp Detail" or "Combination Curb Ramp Detail" when reqd. turning space cannot be obtained)

Site 7:



Use ODOT Standard Drawing RD735 Option G

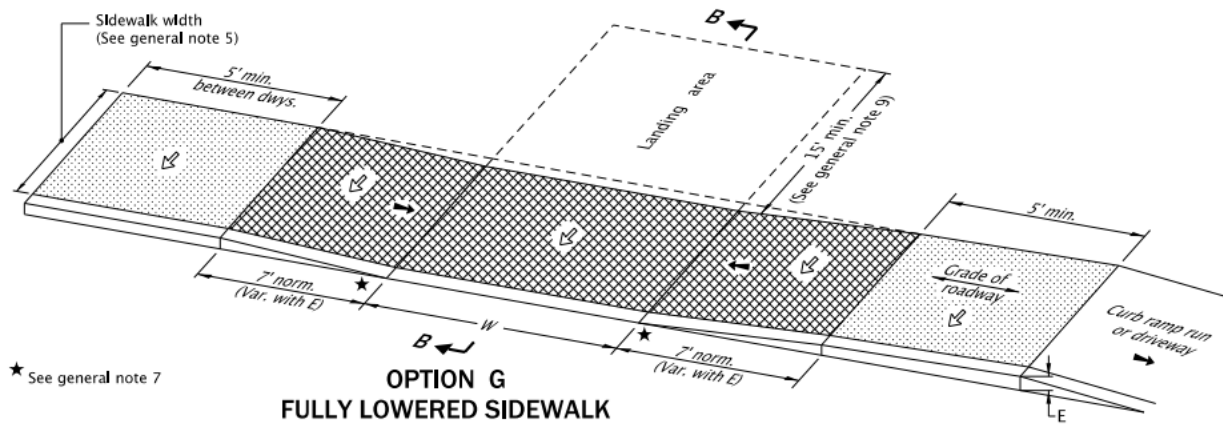



Use ODOT Standard Drawing RD735 Option G

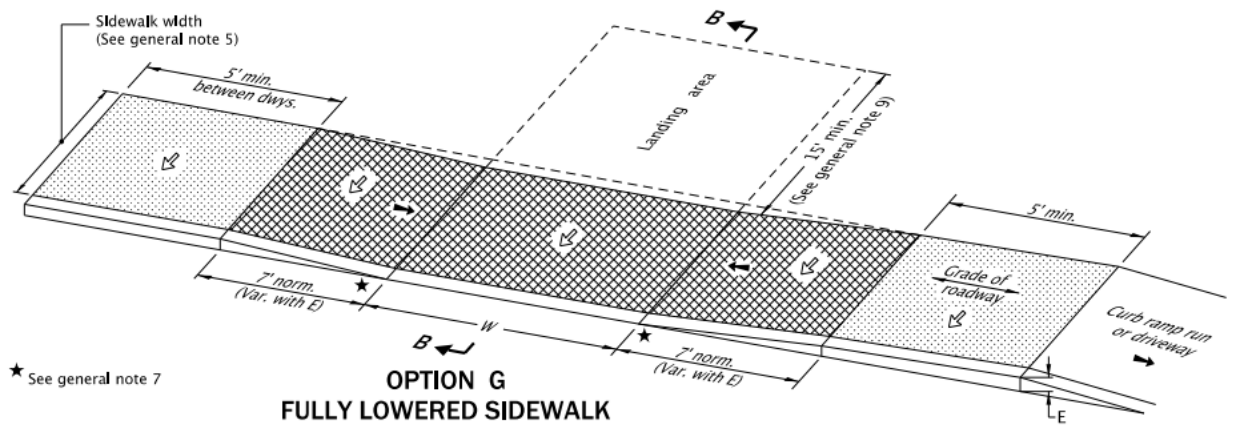

Site 8:



Use ODOT Standard Drawing RD910

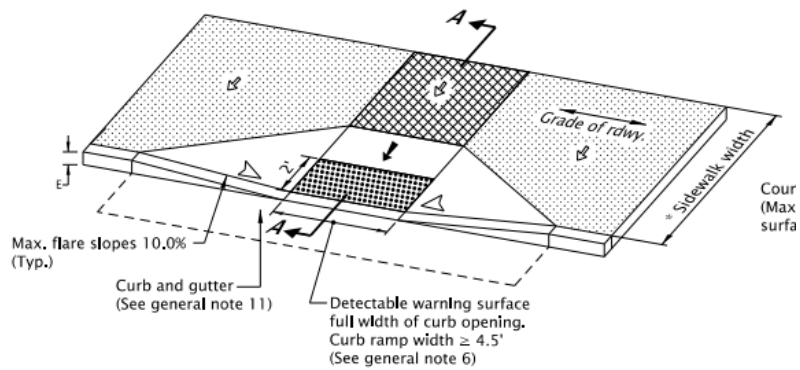

PERPENDICULAR CURB RAMP DETAIL

(Use "Parallel Curb Ramp Detail" or "Combination Curb Ramp Detail" when reqd. turning space cannot be obtained)

Site 9:



Use ODOT Standard Drawing RD910

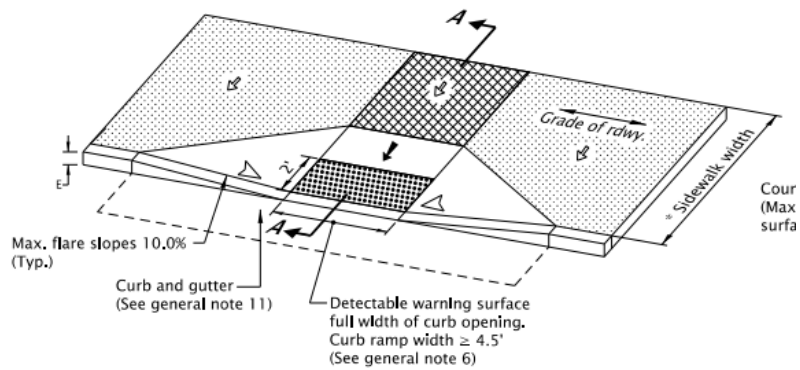

PERPENDICULAR CURB RAMP DETAIL

(Use "Parallel Curb Ramp Detail" or "Combination Curb Ramp Detail" when reqd. turning space cannot be obtained)